

# 8900 SIS, SISJ, SISH, SISJH

Spring stop arm for regular and top jamb mount  
with hold open (SISH, SISJH)

## Installation instructions

08279451 – 09-2019

| EN |



dormakaba 



# Table of contents

<b>1</b>	<b>Technical specifications</b>	<b>3</b>
1.1	Overview	3
1.2	Tools recommended	3
1.3	Handing the door	3
<b>2</b>	<b>Installation - regular mount</b>	<b>4</b>
2.1	Installing the surface closer	4
1.4	Surface closer components	4
2.2	Securing main arm to door/frame	5
2.3	Securing main arm to closer	5
<b>3</b>	<b>Instructions - top jamb mount</b>	<b>6</b>
3.1	Mounting backplate/top plate (BP89)	6
3.2	Installing the surface closer	6
3.3	Securing main arm to door/frame	7
3.4	Securing main arm to closer	7
<b>4</b>	<b>Adjustments</b>	<b>8</b>
4.1	Adjust closing speeds: sweep, latch, backcheck, delayed action	8
4.2	Adjust optional hold open	8
<b>5</b>	<b>Install covers</b>	<b>8</b>

# 1 Technical specifications

## 1.1 Overview

-  Caution: sex nuts are required for attachment of components to unreinforced doors and to wood or plastic faced composite type fire doors, unless an alternative method is identified in the individual door manufacturer's listings.
-  Maximum door opening degree is 180°.
-  Maximum 4-1/2" reveal on top jamb mounts for 110° degree openings.

-  Know the swing of the door which is being installed prior to installation.
-  Verify closer spring size prior to installation.
-  Make sure door efficiently operates prior to installing closer.

## 1.2 Tools recommended

Table 1

Drill bits:	#3 phillips screwdriver
Metal: 7/32" drill bit; 1/4-20 tap	1/2" or 13mm box wrench
Wood: 5/32" bit	10" adjustable wrench
DPK: 1/8"	3/16" hex key
Sex nuts: 3/8"	5mm hex key

## 1.3 Handing the door

Fig.1

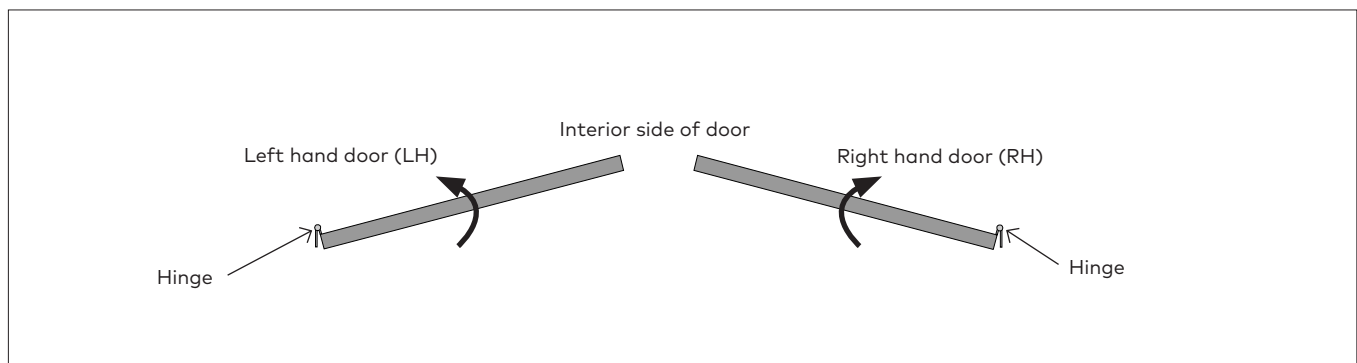

## 1.4 Surface closer components

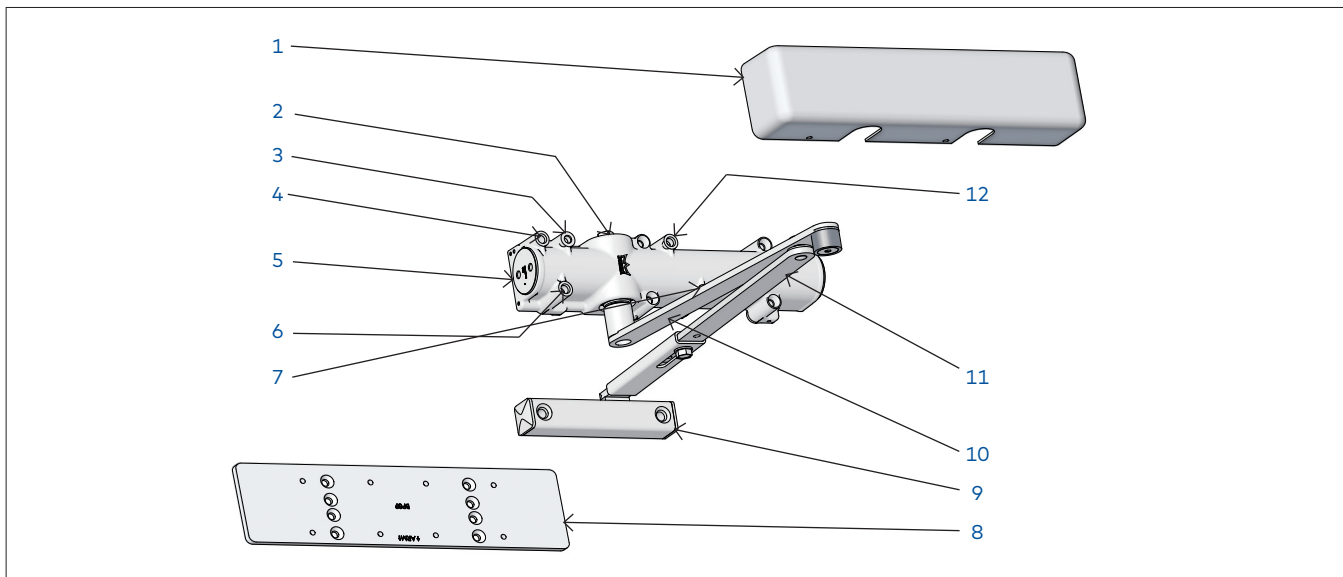

The surface closer is comprised of the following components.

- |                                   |                           |
|-----------------------------------|---------------------------|
| 1. Cover                          | 7. Backcheck adjustment   |
| 2. Pinion                         | 8. Optional backplate     |
| 3. Delayed action adjustment      | 9. Damper assembly        |
| 4. Latch speed adjustment         | 10. Main arm              |
| 5. Closer body                    | 11. Connecting arm        |
| 6. Closing/sweep speed adjustment | 12. Backcheck positioning |

# 2 Installation - regular mount

## 2.1 Installing the surface closer

Fig.2

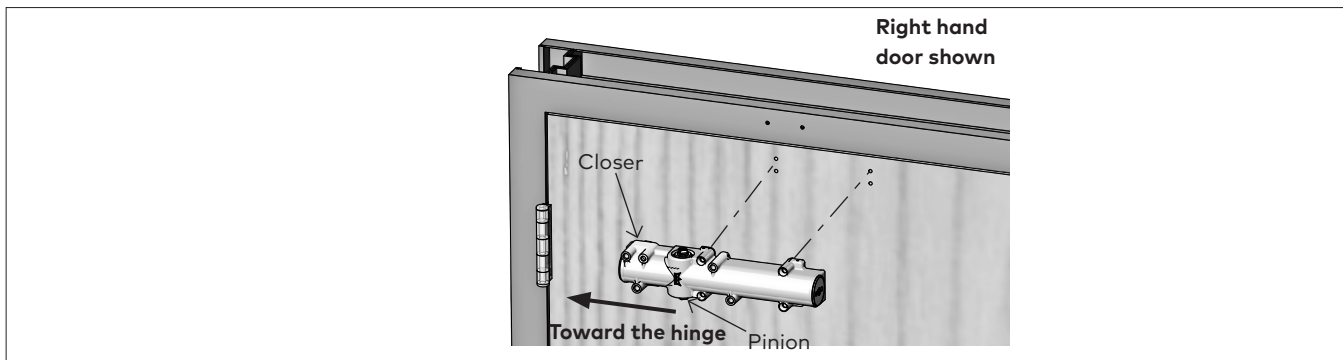

**NOTE: Orient pinion toward the hinge.**

- 2.1.1 Secure closer body to door.
- Use four 1/4-20 x 2" Phillips flat head screws  
[#14 x 2-3/4 PH flat head wood screws]  
provided.

## 2.2 Securing main arm to door/frame

Fig.3

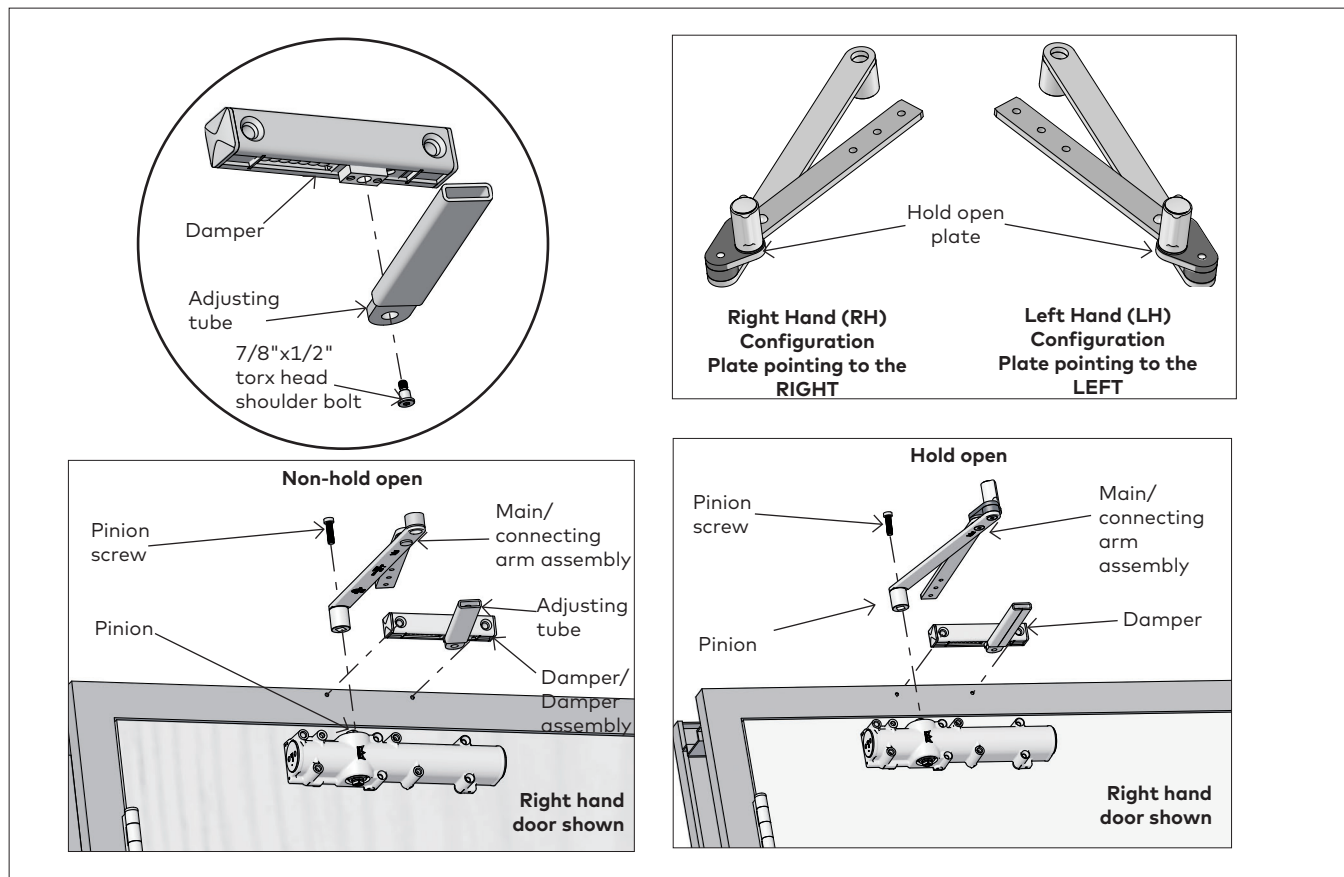

- 2.2.1 Secure adjusting tube to damper.
  - Use one 7/8" x 1/2" torx head shoulder bolt provided.
- 2.2.2 Secure damper assembly to frame.
  - Use two 5/16" x 2" flat head screws [#20 x 2" flat head wood screws] provided.
- 2.2.3 Secure main arm to operator pinion.
- 2.2.4 Use a torque wrench (25 ft-lbs) and provided pinion screw [M8 x 30 socket head cap screw].

**NOTE: To disassemble hold open plate:**

- 2.2.5 Remove both screws from bottom of plate using a 3/16" hex key.
- 2.2.6 Keeping all washers in place, flip plate over to orient as per image above.
- 2.2.7 Re-secure plate with both screws.

## 2.3 Securing main arm to closer

Fig.4

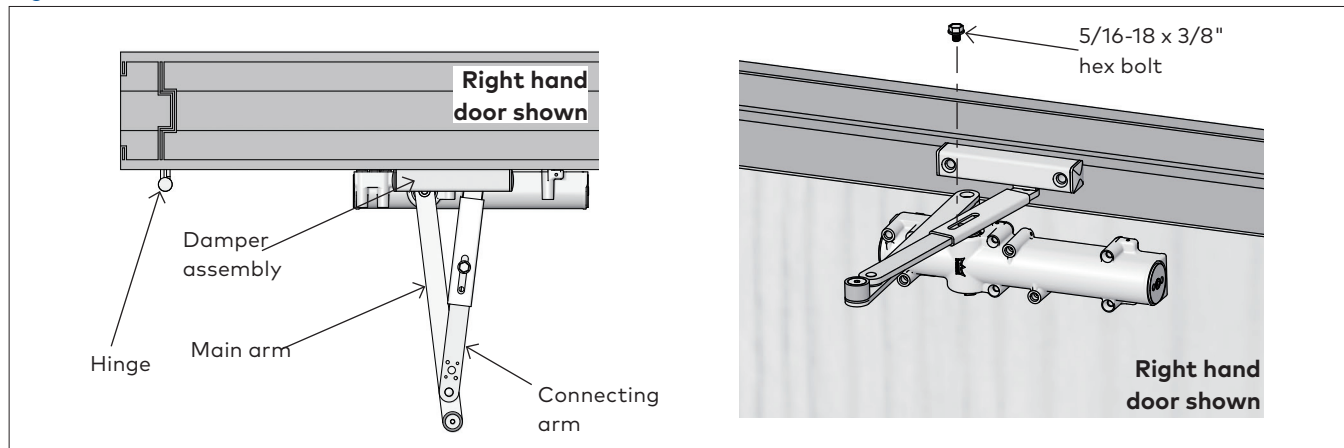

- 2.3.1 Slide end of connecting arm into end of damper assembly.
- 2.3.2 Secure connecting arm and damper assembly.
- 2.3.3 Use provided fastener [5/16-18 x 3/8 hex bolt].

## 3 Instructions - top jamb mount

### 3.1 Mounting backplate/top plate (BP89)

Fig.5

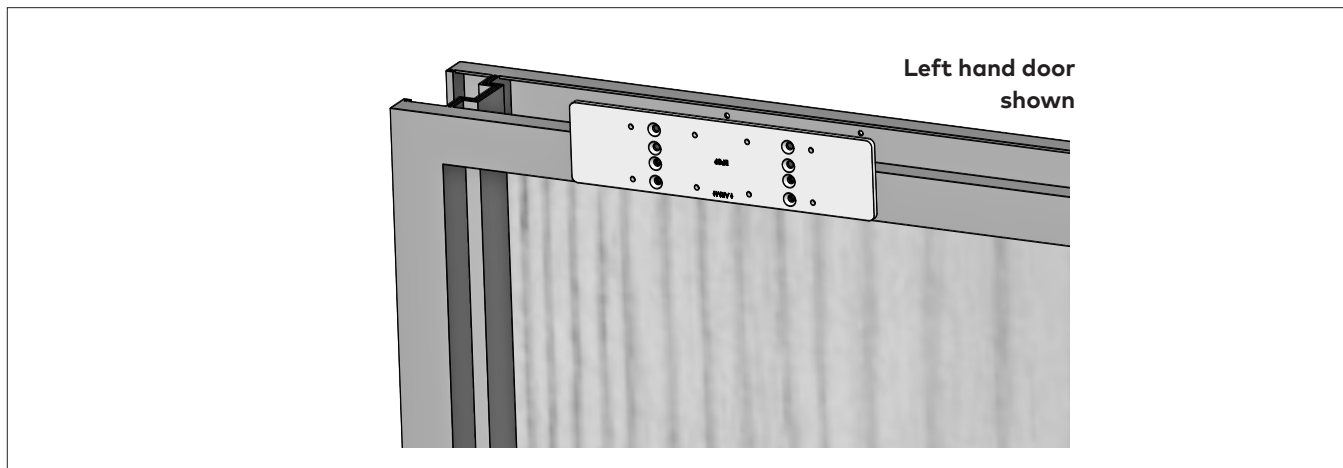

**NOTE:** Backplate is required for frames under 3" in height.

- 3.1.1 Secure plate to frame.
- Use four 1/4-20 x 5/8" flat head screws [#14 x 1-1/2 Phillips flat head wood screws] provided.

### 3.2 Installing the surface closer

Fig.6

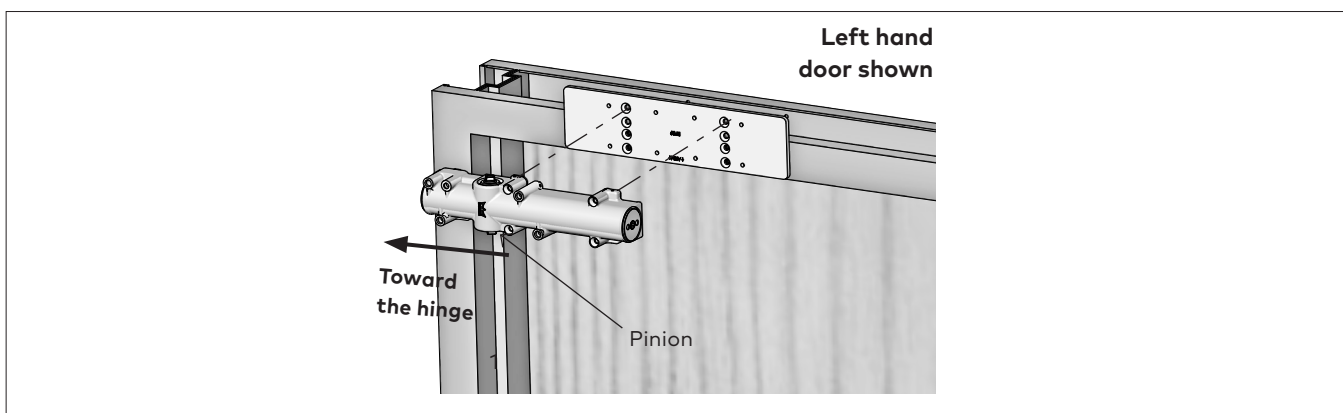

**NOTE:** Orient pinion toward the hinge.

- 3.2.1 Secure closer body to plate.
- Use four 1/4-20 x 1-3/4" Phillips flat head screws provided with the plate itself.

### 3.3 Securing main arm to door/frame

Fig.7

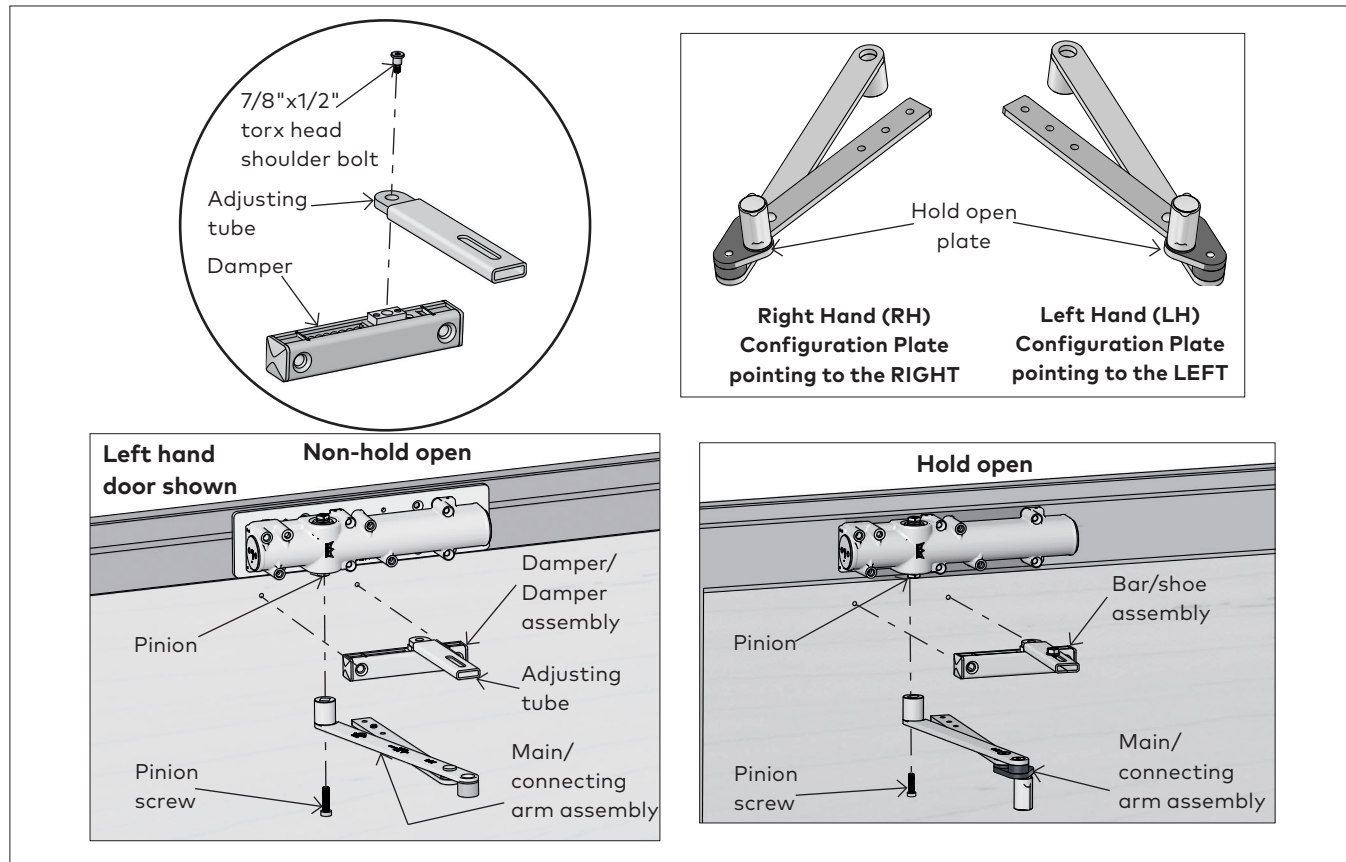

- 3.3.1 Secure adjusting tube to damper.
  - Use one 7/8" x 1/2" torx head shoulder bolt provided.
- 3.3.2 Secure damper assembly to frame.
  - Use two 5/16" x 2" flat head screws [#20 x 2" flat head wood screws] provided.
- 3.3.3 Secure main arm to operator pinion.
  - Use a torque wrench (25 ft-lbs) and provided pinion screw [M8 x 30 socket head cap screw].

**NOTE: To disassemble hold open plate:**

- Remove both screws from bottom of plate using a 3/16" hex key.
- Keeping all washers in place, flip plate over to orient as per image above.
- Re-secure plate with both screws.

### 3.4 Securing main arm to closer

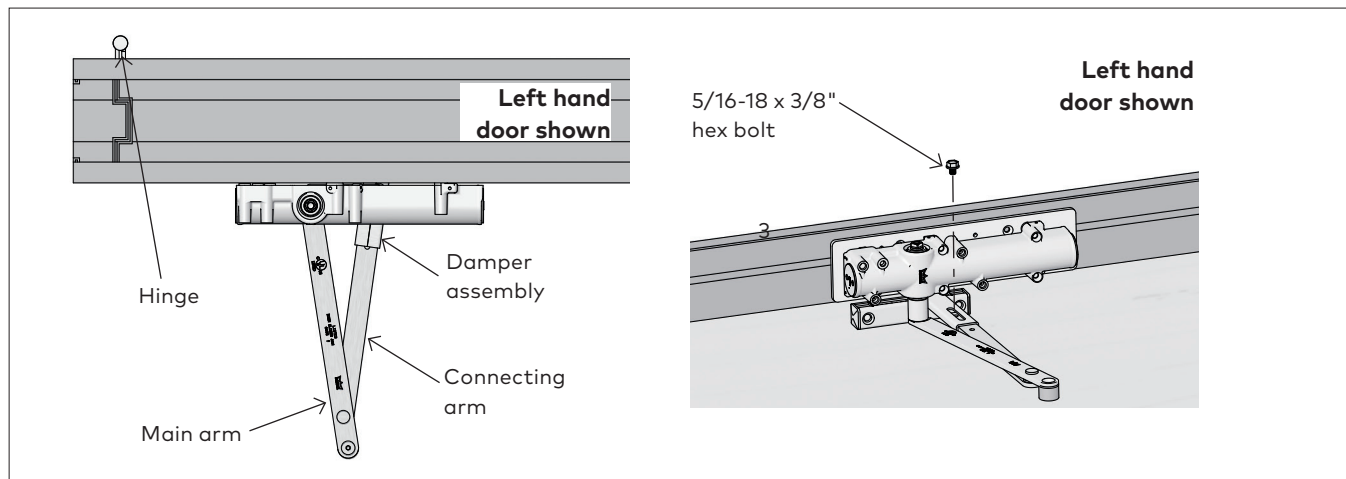

Fig.8





- 3.4.1 Slide end of connecting arm into end of damper assembly.

- 3.4.2 Secure connecting arm and bar/shoe assembly.
- 3.4.3 Use provided fastener [5/16-18 x 3/8" hex bolt].

# 4 Adjustments

-  Confirm closer spring size prior to making any closing speed adjustments.
-  Do not back valve heads out beyond closer casting.

-  Maximum opening angle is 110°.
-  Door should close in 3 to 6 seconds from 90°.
-  Do not close valves completely.

## 4.1 Adjust closing speeds: sweep, latch, backcheck, delayed action

Fig.9

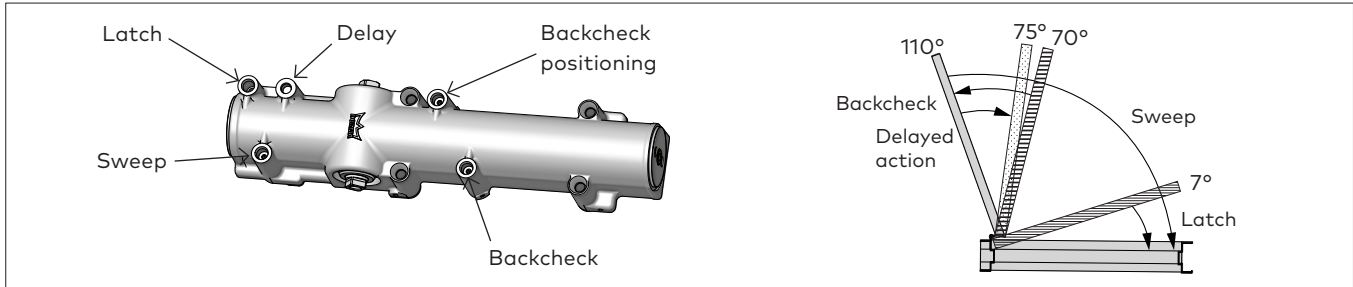

- 4.1.1 Adjust sweep speed for the area from 70° - 10°.
- Increase sweep speed: Turn valve counter-clockwise
  - Decrease sweep speed: Turn valve clockwise
- 4.1.2 Adjust latch speed from 10° - 0°.
- Increase latch speed: Turn valve counter-clockwise
  - Decrease latch speed: Turn valve clockwise
- 4.1.3 Adjust backcheck for the area from 110° - 70°.
- Increase resistance: Turn valve clockwise
  - Decrease resistance: Turn valve counter-clockwise.

- 4.1.4 Adjusting Backcheck positioning will advance approximately 15° in the "ON" position. Shipped from factory fully "ON".
- Turn OFF: Rotate counter-clockwise
  - Turn ON: Rotate clockwise
- 4.1.5 Adjust Delayed Action for the are from 75° - 110°.
- Increase delay: Turn valve counter-clockwise
  - Decrease delay: Turn valve clockwise

## 4.2 Adjust optional hold open

Fig.10

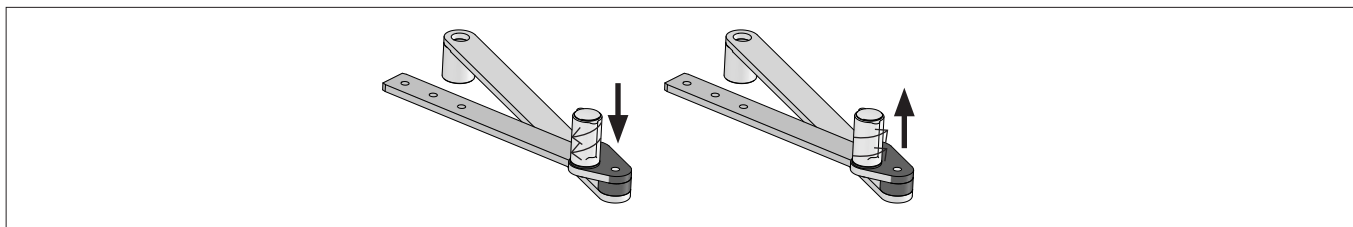

- 4.2.1 Enabling or disabling hold open.
- 4.2.2 Twist hold open handle up or down to loosne or tighten, respectively, the hold open capacity.
- 4.2.3 Engaging or disengaging hold open.

- 4.2.4 Engaging hold open: push door open until hold open ball connects with detent in handle.
- 4.2.5 Disengaging hold open: pull door to pop hold open ball out of detent.

# 5 Install covers

Fig.11

